



Amfibi™ Double

HighBack Hygiene Commode



Amfibi™ Double

HighBack Hygiene Commode

Amfibi Double HighBack is a further development of our much appreciated Amfibi concept. It is equipped with a high, upholstered back with upholstered back including neck rest and integrated seat with rear opening. The high backrest provides soft yet stable support and its lower section is fitted with a pliant lumbar support for additional comfort. The seat with the opening to the rear was designed to meet the wishes of GATE customers; it provides a natural, more hygienic working method.

High, upholstered backrest

The high backrest provides soft yet stable support. It is easy to clean and can be replaced as necessary.

Integrated neck rest

The integrated height-adjustable neck rest is available in two sizes, M and L.

Pliant lumbar support

The lower section of the backrest is fitted with a pliant lumbar support for additional comfort.

Tilt function

Amfibi Double can be inclined 5 degrees forward to 25 degrees rearward. This makes it easy to use for personal hygiene and when sitting down or getting up. The tilt function also improves the working environment and reduces strain on personnel.

Lockable armrests

The armrests can be flipped up and locked in position to make it easier for the patient to be of help with the transfer.

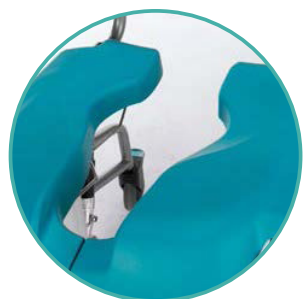

Integrated seat with the opening to the rear

The seat has a soft, resilient, ergonomic design for the best comfort possible. The opening to the rear provides the carer with a natural, more hygienic working method.

Swing-away, detachable footrests

An infinitely variable seat height from 53 all the way to 82 cm means the chair will fit every patient and reduce staff workload to a minimum.

Lockable castors

All four castors are lockable.



Electronics for height and tilt operation

The high-backrest design means that the electronics for height and tilt operation have been located in a protective box at the rear and that wiring has been integrated in a better way than previously.

Plastic or metal

A guide is available for Amfibi as an accessory. Note that the guide is available in different versions to suit plastic or metal bedpans. See *accessories*.



Technical specifications

Dimensions apply to walkers with 125mm castors

CE marked according to MDD 93/42/EEC

| Product Code | Product | Width | Max user weight | Seat Depth | Seat Height | Internal dimension |
|--------------|------------------------|-------|-----------------|------------|-------------|--------------------|
| RHGA-56-275 | Amfibi Double HighBack | 60cm | 150kg | 45cm | 53-82cm | 52cm |

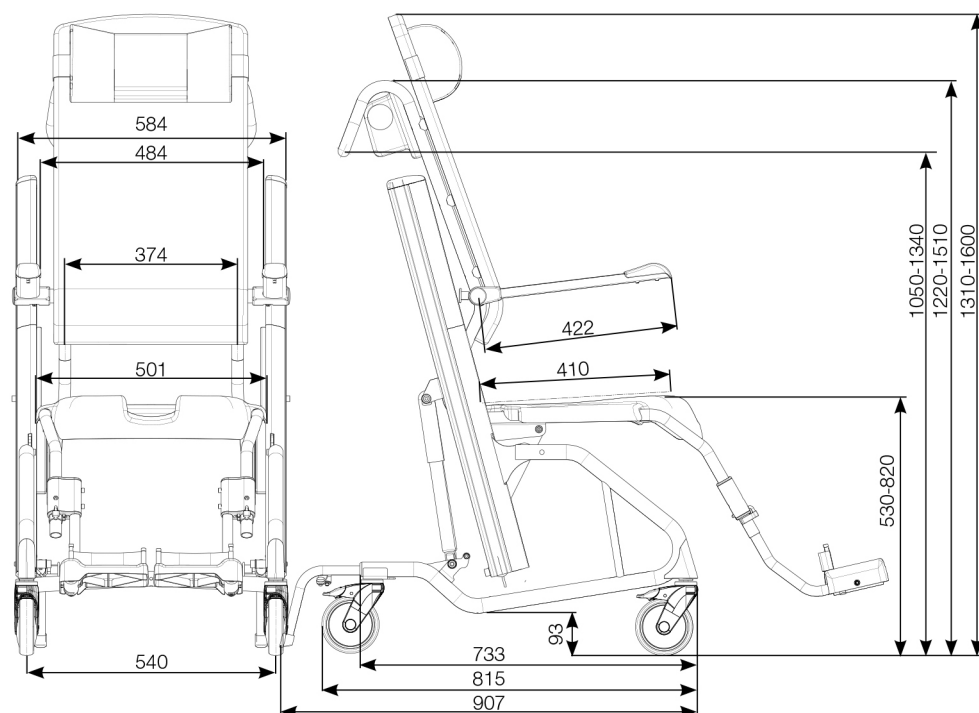

Accessories



Soft Seat
RHGA-56-206



Heel Loops
RHGA-56-220



Safety Bar for DB
RHGA-56-212-DOUBLE



Side Supports
RHGA-56-216



Splash Guard
RHGA-56-213



Waste Container
RHGA-56-209

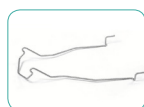

Waste Container Holder
RHGA-56-218



Safety Belt Hip
RHGA-56-217



Safety Belt Chest
RHGA-56-229



Amputee Support
RHGA-56-228-L/R



Calf Support
RHGA-56-227-L/R



Footrest
RHGA-56-257-L/R



Calf Strap
RHGA-56-225



Castor with brake
(Various sizes)

SHI200115-v2.2

Designed to meet needs

GATE hygiene chairs have a unique pillar design for quick and easy seat height adjustment. There is a choice of manual or electric adjustment to suit various needs. Amfibi fits most people no matter how tall, and staff will not need to waste time and energy looking for a suitable hygiene chair for each situation.

Everyday life improved

And it goes without saying that Amfibi never compromises on user comfort and personnel ergonomics. Individually adaptable comfort and function makes the hygiene chair a much more

pleasant experience for patient and healthcare staff alike. Amfibi is manufactured from corrosion-proof materials and its actuator can withstand high pressure hot water (IP66).

Best possible comfort

Users often sit in a chair for a long while when washing or taking a shower, and this can become very trying. Amfibi was created to provide extremely high comfort. The seated Amfibi user is able to assume a position for the best possible comfort. The hygiene chair quickly adapts to a personal fit with the aid of easily operated settings, and all models are height-adjustable.

The Amfibi's seat and back are adapted for an upright posture that does not close the pelvis. The ergonomic design minimises pressure on the hips, tendons and blood vessels, while its rounded front edge contributes to a comfortable leg position.

The new, soft, water-repellent backrest that provides the best possible comfort and hygiene is unique to Amfibi (accessory). It is easily adjustable for best support and seat depth.

GATE hygiene chairs are available in three different versions. Amfibi Double is our most advanced, versatile hygiene chair; it is adjustable in height and tilt angle of inclination. Amfibi XL was designed for the bigger, heavier patient, while Basic is our simplest version.

Other Commodes in the Amfibi™ range



Amfibi™

Basic Hygiene Commode

Amfibi Basic was developed to meet most basic needs. With its attractive price it provides a lot of hygiene chair at low cost. **Basic** has adjustable seat height and a wide range of accessories that make it easy to individually adapt the chair to suit every patient's needs.



Amfibi™

XL Hygiene Commode

Amfibi XL was designed for the bigger, heavier patient and therefore provides extra space and strength and electrical height adjustment. Maximum user weight is 250 kg.



Amfibi™

Double Hygiene Commode

Amfibi Double is GATE's most advanced and versatile hygiene chair. It is equipped with twin electric drives, electrically operated raising and lowering and electrically operated tilt. The chair can be adjusted steplessly even when the patient is in the chair.

Also Available



Bure™

Rise & Go™

Bure Rise & Go is an all-round solution that saves space, time and money. Instead of purchasing both hoists and walkers it is probably often sufficient to acquire the flexible, cost effective **Bure Rise & Go**.



Bure™

StandTall Walkers

Apart from being an excellent aid for getting patients up and about, the **StandTall Walker** is also a valuable rehabilitation tool. Rehabilitation using the **StandTall Walker** keeps the patient's muscles and alimentary canal active and contributes to improving the general condition of the otherwise bedridden.



Distributed by:

For more information, or to find your nearest dealer, call us on 1300 791 404 or visit www.gaterd.com.au

